

STP

INCH serration
3 jaws

Stationary chuck, pneumatic Ø 125 - 280 mm

- built-in cylinder
- with THROUGH-HOLE

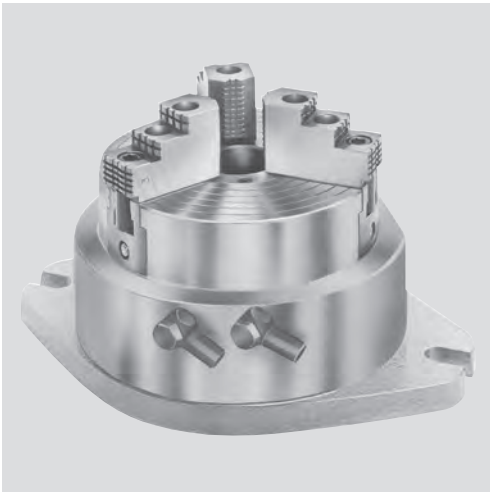

Application/customer benefits

- Self centering stationary chuck used on milling machines/machining centers/special machines
- Low profile – large open center
- Easy installation on the machine

Technical features

- Stationary chuck consisting of a 3 jaw chuck with a built-in pneumatic cylinder
- Operating pressure from 2 to 10 bar

Caution! Filtered and oiled, operating air required

Standard equipment

- 3 jaw chuck
- 1 set T-nuts with bolts
- 1 set of soft blank top jaws
- 2 elbow fittings G1/4" (G1/8" on STP 125)

Ordering example

- 3 jaw chuck fixture STP 280
- or
- 3 jaw chuck fixture STP 160

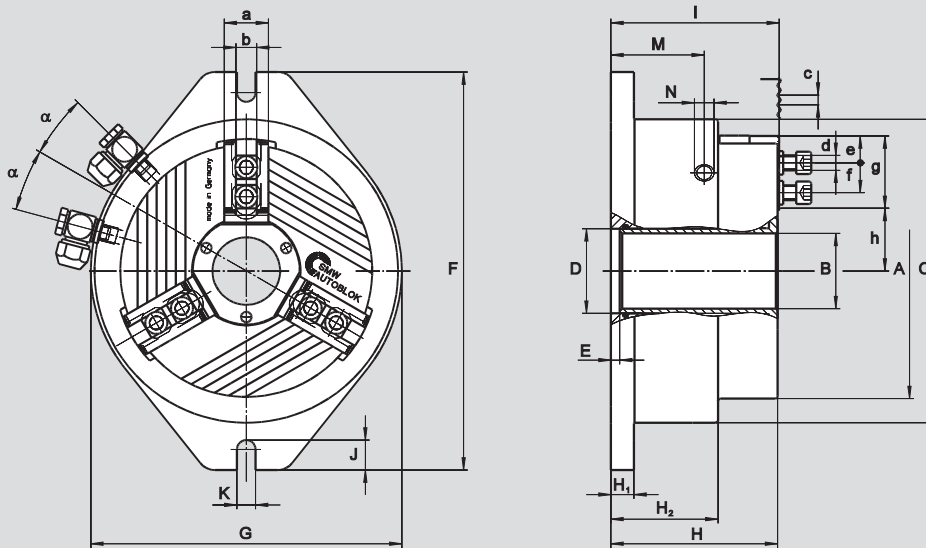

Subject to technical changes
For more detailed information please ask for customer drawing

Technical data

SMW-AUTOBLOK Type Id. No.			STP 125 013904	STP 160 013905	STP 240 053273	STP 280 052810
	A	mm	136	171	240	284
	B	mm	26	38	78	92
	C	mm	156	201	250	316
	D H6	mm	34	46	86	102
	E	mm	8	7.5	7	6
	F	mm	220	275	320	400
	G	mm	160	206	250	316
	H	mm	102.5	130	134	155.5
	H1	mm	14.5	19	18.5	23.5
	H2	mm	66	83	86	97.5
	I	mm	104	132	135.5	157
	J	mm	22	24	24	30
	K	mm	13	15	15	18
	M	mm	57	72	75	86
Pneumatic connections	N	inch	G 1/8"	G 1/4"	G 1/4"	G 1/4"
	a	mm	25	30	36	44
	b f7	mm	12	14	17	21
Serration	c	inch	1/16" x 90°	1/16" x 90°	1/16" x 90°	1/16" x 90°
Bolt ISO 4762 12.9	d	mm	M8 x 30	M10 x 35	M12 x 35	M16 x 40
	e	mm	4	6	8	12
T-nuts distance	f	min./max.	17/25	17/31	22/41.5	25/51
Serration length	g	mm	40	50	59	75
	h	min./max.	25.9/28.9	24.9/37	57.7/61.9	70/65
	alpha		15	15	15	7.5
Radial jaw stroke		mm	3	4.1	4.2	5
Operating pressure	min./max.	bar	2/10	2/10	2/10	2/10
Piston area		cm²	129	206	290	532
Air consumption at 6 bar		l	1	2.4	5.5	6.6
Weight (without top jaws)		kg	19	21	40	56

- Top jaws
- T-nuts

MHB-D Hardened reversible top jaws

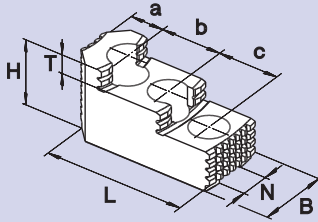

Chuck	STP 125	STP 160	STP 240	STP 280
Jaw type	MHB-D 125	MHB-D 160	MHB-D 200	MHB-D 251
Jaw Id. No. (set)	12081306	12081636	12082036	12083036
B	30	34	40	5
H	34	39	45	56
L	58	65	82	105
T	8.5	10	10.5	13.5
N	12	14	17	21
Serration	1/16" x 90°	1/16" x 90°	1/16" x 90°	1/16" x 90°
a	13	18	19	26
b	16	16	23	30
c	16	16	23	30
kg/set	0.6	0.9	1.7	2.85

AWB-D Soft top jaws

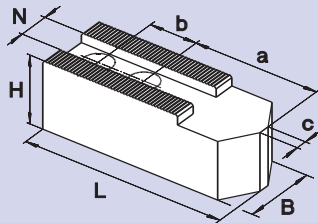

Chuck	STP 125	STP 160	STP 240	STP 280
Jaw type	AWB-D 125	AWB-D 165	AWB-D 200	AWB-D 250
Jaw Id. No. (set)	12071300*	035954	081616	081618
B	30	40	40	50
H	30	40	40	50
L	60	80	90	120
N	12	14	17	21
Serration	1/16" x 90°	1/16" x 90°	1/16" x 90°	1/16" x 90°
a	29	43	53	70
b	16	22	22	28
kg/set	0.9	2.0	2.7	5.1

* Id. No. is per piece.

NST T-nuts

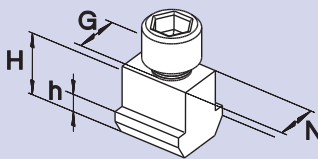

Chuck	STP 125	STP 160	STP 240	STP 280
T-nut type	NST 12	NST 14	NST 17-4	NST 21-5
T-nut Id. No.	089810	013863	013864	033429
N	12	14	17	21
H	21.5	26.5	26.5	30
h	7.5	9.5	9.5	11
G	M8	M10	M12	M16
Bolt ISO 4762 12.9	M8 x 30	M10 x 35	M12 x 35	M16 x 40
Tighten torque	30	50	70	150

